

Electromechanical Swing Clamp Unit

ESS

Application area

- For medium and larger presses
- For clamping upper dies
- For dies or adapter plates with identical dimensions and U-recesses
- Stationary installation on the slide edge

Mode of operation

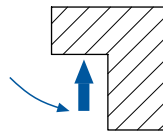
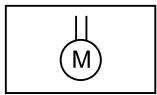

- An electric motor with gear drive provides the clamping force.
- The swing movement is carried out by means of a mechanical guide.

Description

By means of a gear drive an electric motor causes a nut to rotate. Through this a tie bolt and a tie rod attached to it are moved up and down. The swing movement is effected by restricted guidance. When the unit is unclamped and the tie rod swung out the clamping area is completely free. Energy is only required during the process of clamping and unclamping. The clamp unit is mechanically self-locking. The clamping force is monitoring continuously.

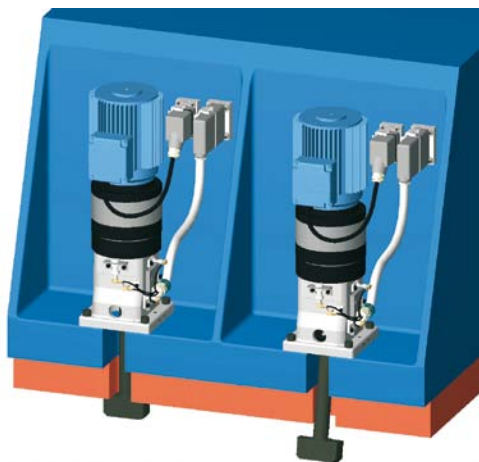

Advantages

- Mechanically self-locking
- Electric monitoring of all functions
- Fully automated operation
- Large clamping dimension tolerance
- Continuous clamping force monitoring

Accessories

- Limit switches / cables
- Plug connectors

Technical data

Type	ESS 60	ESS 120	ESS 240
Clamping force [kN]	60	120	240
Max. loading force [kN] ¹⁾	100	200	400
Clamping dimension tolerance [mm]	+/- 7		
Stroke [mm]	17		
Clamping speed [mm/s]	2,2		
Motor: Type	three-phase		
Supply voltage	400 V 50 HZ		
Limit switches: Number / type	• Four inductive proximity switches		
Supply voltage	• PNP normally open; 10-30 V DC		
Connection type	• Plug-in type (M8x1)		
Designation	• Tie rod swung in	S4	
	• Tie rod swung out	S5	
	• Continuous clamping force monitoring	S6	
	• Maximum upper tie rod position (clamped without die)	S7	
Max. operating temperature [°C]	70		
Weight [Kg]	40	43	48

¹⁾ Mechanical damage may occur at higher loads.
Fixing is achieved with four screws M12, DIN 912 strength class 8.8 (not included).

Electromechanical Swing Clamp Unit

ESS

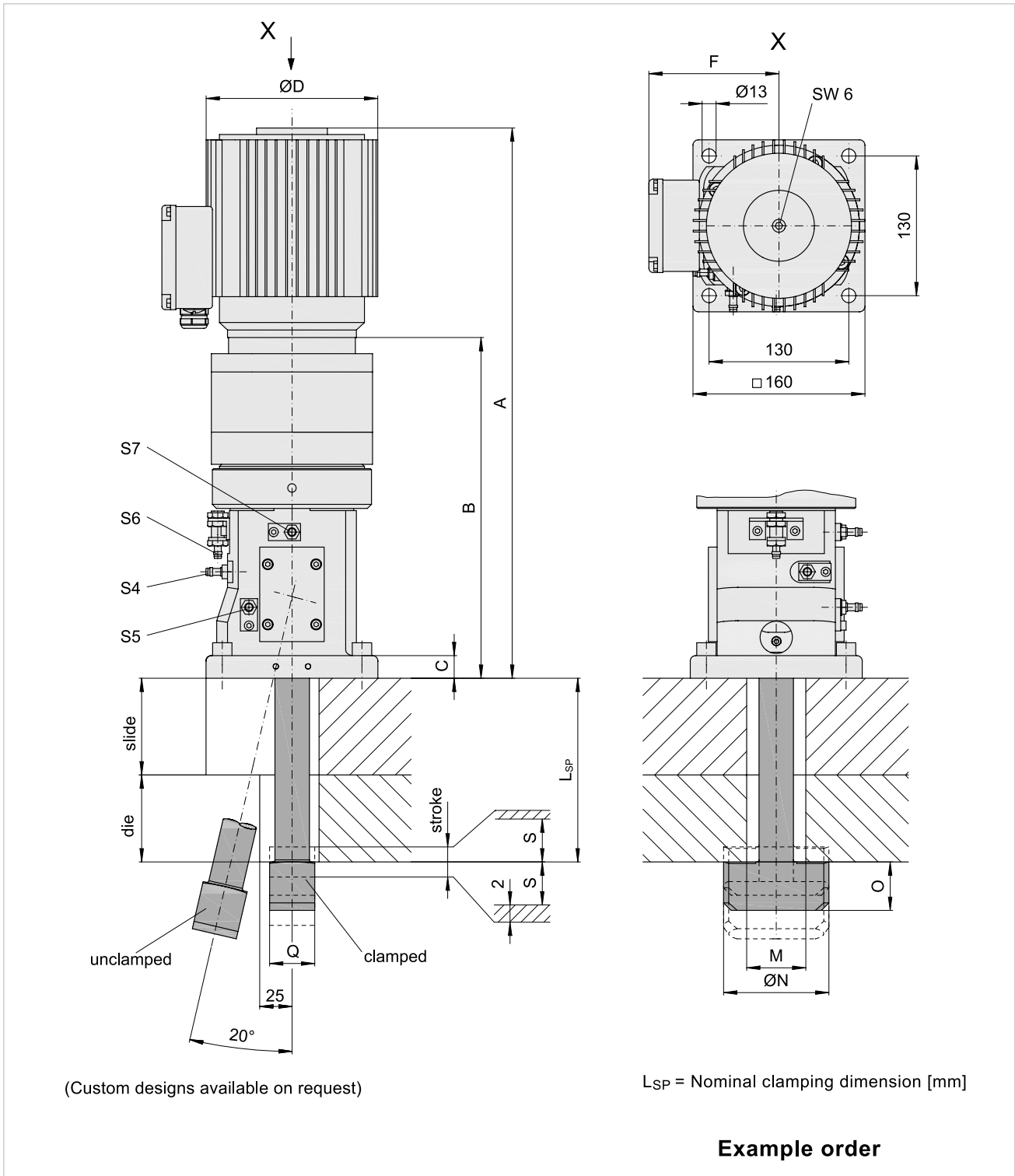

(Custom designs available on request)

L_{SP} = Nominal clamping dimension [mm]

Example order

ESS 120 - 150

Type _____

L_{SP} _____

Type	stroke	S	A	B	C	ØD	F	M		ØN	O	Q	L _{SP} min.
								min.	max.				
ESS 60	17	7	488	308	20	150	102	45	50	80	30	36	60
ESS 120	17	7	513	318	20	160	123	50	60	98	45	42	70
ESS 240	17	7	604	371	30	160	123	65	70	120	60	62	75